



ROLL IN REFRIGERATED CABINET 1 LOCKABLE GLASS DOOR WITH LED LIGHT
 Capacity. 700LTR (2/1GN)
 Temperature Range. -2°C to +5°C @ +43°C

Main Features

Extended Warranty – 5/2yrs Parts and Labour

High-Performance – 60mm high-density (45kg/m3) rigid foam polyurethane insulation, Zero Ozone Depleting – (100% CFC & HCFC Free)

Adaptive Precision Controller – adaptive and remarkably flexible IP65 Water & Dust Ingress Protected 'Intelligent' controller with (LCD) Liquid Crystal Display for clear text monitoring of temperatures, functions, cycles, alarms, compressor running, defrost cycle, dripping indicator, temperature & humidity level indicator, cooling, door open alarm, and clean condenser. Built-in features include; audible and visual multi-function alarm alert system, fan speed management system, auto self-diagnostics system, and Intelligent Defrost System

Intelligent Defrost Systems (IDS) – demand responsive, reliable and highly-efficient 'hot-gas' defrost eliminating the need for extra energy input will only initiate when necessary & only when necessary without consideration of previous defrost cycles and without the need for predetermined time-based defrost intervals

AISI304 Cr Ni 18/10 Construction – exterior / interior in high-grade food safe stainless steel interior includes insulated floor base, heavy-duty ramp, and internal perimeter bumper

Adjustable Humidity Control – adjustable humidity level from between 60% - 90% in increments of 1% via the controller allowing an ideal level of humidity for any food type being stored

Soft-start Refrigeration System – greatly reduces power absorption on cooling cycle start-up and reduces typical wear and tear on refrigeration components

Double Glazed Argon E Fully Tempered Safety Glass Door – reversible with full-height radius door handle and mechanical key lock, self-closing with 180° opening and 'stop' (remains open unassisted) at 95° with integrated micro-switch to facilitate fan 'Cut-off' and 'Door Open' alarm

Door Gaskets – each refrigerated cabinet to be fitted with easily replaceable balloon type magnetic door gaskets to guarantee a highly efficient door seal and to increase overall thermal efficiency

Automatic Fan Cut-off & Door Open Alarm – door/s fitted with a micro switch to turns off cooling fans when a door is opened and reduce ambient air in-flow ensuring circulated cold air remains within the refrigerated cabinet. Audible and Visual 'Door Open' alarm activates when a door is left open or ajar

Adjustable Humidity Control – adjustable humidity level from between 60% - 90% in increments of 1% via the controller allowing an ideal level of humidity for any food type being stored

Auto Self-diagnostics – is self-adjusting to ambient and operational conditions, continually accesses the performance of the refrigeration system and efficiency

Inbuilt Defrost Waste Vaporizer – hot-gas disposal device to eliminate the defrost water (drainage not required)

Over-current / Thermal Fuse Protection – inbuilt thermal protection in the event of a thermal compromise to prevent, and limit damage to equipment's electrical components and reduce the risk of harm to the operator caused by overloads, or electrical safety breaches in unusual circumstances

Service & Maintenance – facilitated via electronic controller to report a precise log of operating temperatures, cycles & alarm event history available in real time to service technicians, self-diagnostic test can be launched to ensure parameters are correct set to guarantee optimum operating capacity upon servicing/maintenance

Environmentally-friendly R290 – for high performance and significantly improved energy efficiency of up to 40% by means of unparalleled efficiency

Manufacturer Warranty. 5 Years Parts & 2 Years Labour
Temperature Range. -2°C to +5°C
Rated Ambient Class. +43°C (T Class)
Internal Capacity. 700LTR (2/1GN)
Origin. Italy

Model VRI7.1PV

Electrical Specification

Supply voltage / Frequency. 240V / 50Hz / 1Ph
 Connection rating. 3.4Amps
 Connected load. 816Watts - 0,81kW

Key Information: Integral Versions (R290 / R404a)

Internal volume. 700 litres (2/1GN)
 Number door/s. 1(lockable)
 Type of door. (Double Glazed Argon E Tempered Safety) Glass Door
 Door hinged. Right hand side
 Drainage. Not Required
 Minimum temperature set point. -2°C
 Maximum temperature set point. +5°C
 Ambient class. +43°C (T Class)
 Adjustable humidity (adjustable in 1% increments). 60% to 90%
 Minimum clearance for maintenance. 350mm
 External dimensions, Width. 880mm
 External dimensions, Depth. 880mm
 External dimensions, Height. 2190mm
 Overall depth with Door/s open. 1644mm
 Interior Dimensions. (mm) (1)690Wx750Dx1720H
 Insulation thickness. 60mm
 Insulation density. 45kg/m3
 Type of external material. AISI304 Cr Ni 18/10
 Type of internal material. AISI304 Cr Ni 18/10

Refrigeration Data (R290 / R404a)

Controller type. Electronic
 Refrigerant type. R290 / R404a
 Refrigerant Gas Quantity. 120grams / 320grams
 Compressor power. 1/2hp / 1/2hp
 Cooling Capacity @ +43°C. 650Watts / 540Watts
 Cooling Capacity @ +32°C. 820Watts / 655Watts
 Evaporator Temp. -10°C
 Cooling system type. Ducted Forced Air
 Defrost type. Hot Gas (IDS)
 Defrost waste disposal. Hot Gas Vaporizer
 Net / Shipped Weight. 280kg / 292kg

Marks of Conformity

HACCP Certified, 2006/42/CE, NF, EN 60335-1, EN 60335-2-89, EN 55014-1, EN55014-2, EN 61000-3-2, EN 61000-3-3, 2004/108/CE, RoHS, RAEE, WEEE, REACH

Included Accessories

Door lock. 1
 LED internal lighting. Included
 Insulated floor base & ramp. Included
 Internal bumper or 'nudge' bar. Included

Versions Available

Remote Version. (without inbuilt refrigeration unit) VRR17.1PV
 Solid Panel Stainless Steel Doors. VRI7.1P
 Low-temperature (Freezer). VRI7BT.1P
 Freezer Triple Glazed Argon E Tempered Safety Glass Door VRI7BT.1PV

Optional Accessories	
CPV7	Core probe
OZONEV7	Ozone steriliser
STAMPANTE/V	HACCP Printer
KSC.M	Electronic Door/s Locks (password protected)
PVTN	Double Glazed Argon E Tempered Safety Glass Door/s
PVBT	Triple Glazed Argon E Heated Tempered Safety Glass Door/s
R404a	R404a refrigerant gas
CO2	Transcritical (for remote cabinets only)

Remote Cabinet Data & Notes

Refrigeration Duty: 540Watts @ -10°C

Remote Connections:
 B - Exit tube evaporator (suction tube) Ø 10mm
 C - Entry tube evaporator (liquid line) Ø 8mm
 D - Power lead 10Amp 3 pin

No tundish/waste drain required - auto disposal device fitted as standard

Notes: +350mm clearance above technical compartment in order to facilitate service/maintenance access, and to allow for adequate ventilation

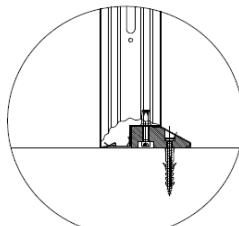
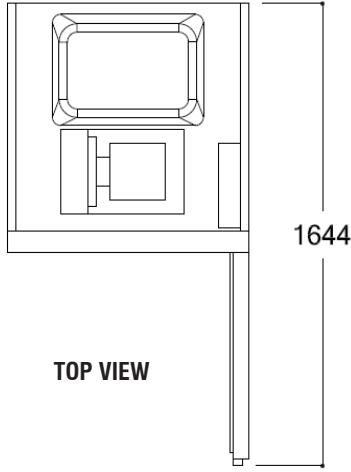
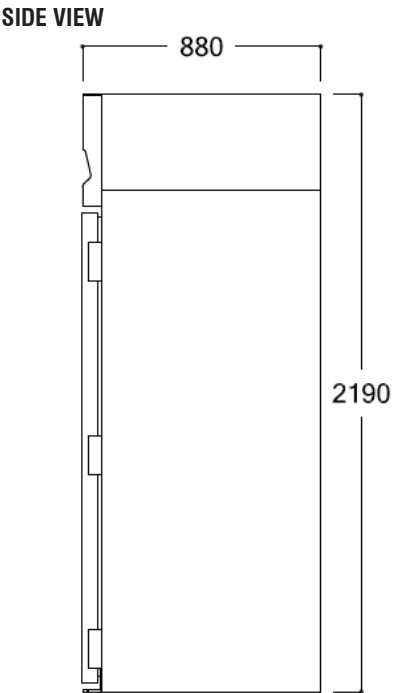
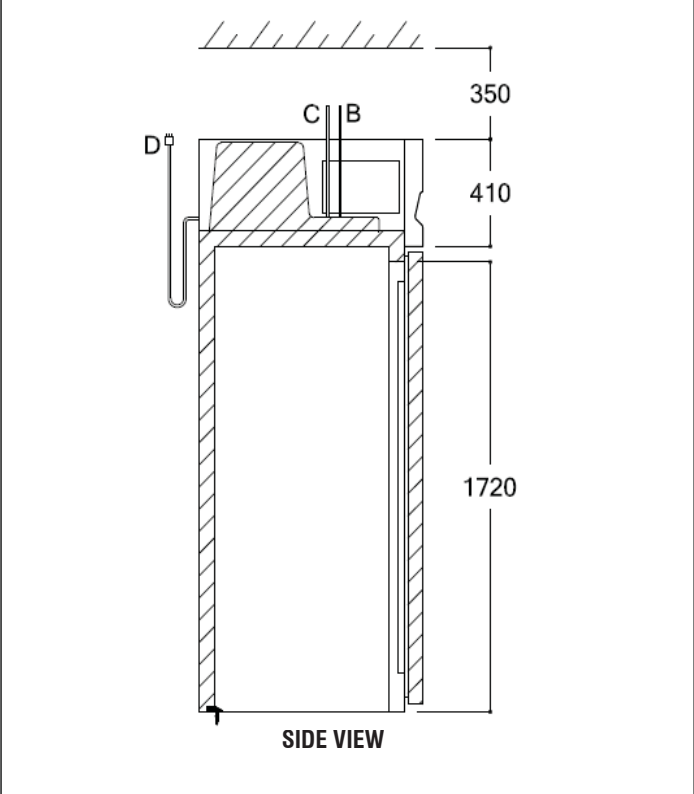
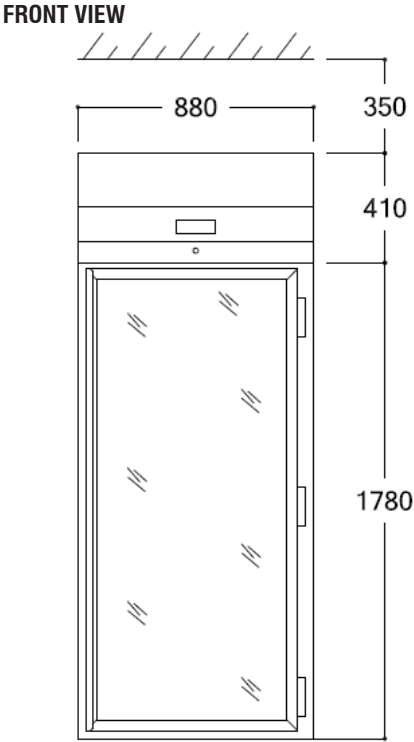

Masonry Floor Fixture

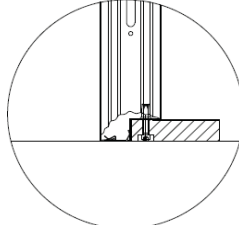

Insulated Floor Fixture